

ELIMINATOR[®]

LIGHTING



PAR38EL

User Manual

©2023 **Eliminator Lighting** all rights reserved. Information, specifications, diagrams, images, and instructions herein are subject to change without notice. Eliminator logo and identifying product names and numbers herein are trademarks of Eliminator Lighting. Copyright protection claimed includes all forms and matters of copyrightable materials and information now allowed by statutory or judicial law or hereinafter granted. Product names used in this document may be trademarks or registered trademarks of their respective companies and are hereby acknowledged. All non-Eliminator brands and product names are trademarks or registered trademarks of their respective companies.

Eliminator Lighting and all affiliated companies hereby disclaim any and all liabilities for property, equipment, building, and electrical damages, injuries to any persons, and direct or indirect economic loss associated with the use or reliance of any information contained within this document, and/or as a result of the improper, unsafe, insufficient and negligent assembly, installation, rigging, and operation of this product.

Eliminator Lighting

6122 S. Eastern Ave. Los Angeles, CA. 90040
323-582-2650 | Fax 323-532-2941 | www.adj.com | info@adj.com

ADJ SUPPLY Europe B.V

Junostraat 2 6468 EW Kerkrade, The Netherlands
+31 (0)45 546 85 00 | Fax +31 45 546 85 99
www.adj.eu | info@adj.eu

ADJ PRODUCTS GROUP Mexico

AV Santa Ana 30 Parque Industrial Lerma, Lerma, Mexico 52000
+52 (728) 282-7070

DOCUMENT VERSION



Due to additional product features and/or enhancements, an updated version of this document may be available online. Please check www.adj.com for the latest revision/update of this manual before beginning installation and/or programming.

Date	Document Version	Software Version >	DMX Channel Mode	Notes
09/06/23	1.0	N/A	N/A	Initial release

CONTENTS

General Information	4
Limited Warranty (USA Only)	5
Warranty Returns	6
Safety Guidelines	7
Maintenance Guidelines	9
Overview	10
Installation	11
Lamp Replacement Trouble Shooting Frequently Asked Questions	13
Specifications Dimensional Drawings	14

GENERAL INFORMATION

INTRODUCTION

Please read and understand all instructions in this manual carefully and thoroughly before attempting to operate this product. These instructions contain important safety and use information.

UNPACKING

This product has been thoroughly tested and has been shipped in perfect condition. Carefully check the shipping carton for damage that may have occurred during shipping. If the carton appears to have been damaged, carefully inspect your product for damage and be sure all accessories necessary to assemble the product have arrived intact. In the event that damage has been found or parts are missing, please contact our customer support team for further instructions. Please do not return this product to your dealer without first contacting customer support at the number listed below. Please do not discard the shipping carton in the trash. Please recycle whenever possible.

CUSTOMER SUPPORT

Tel: (323) 213-4592 | Fax: (323) 582-2941

www.adj.com | support@eliminatorlighting.com

Warning! To prevent or reduce the risk of electrical shock or fire, do not expose this unit to rain or moisture.

Caution! There are no user serviceable parts inside this unit. Do not attempt any repairs yourself, as doing so will void your manufacturer's warranty. In the event that your unit requires service, please contact Eliminator Lighting for assistance.

PLEASE recycle the shipping carton when ever possible.

LIMITED WARRANTY (USA ONLY)

- A. Eliminator Lighting, an ADJ Products, LLC brand, hereby warrants, to the original purchaser, Eliminator Lighting products to be free of manufacturing defects in material and workmanship for a prescribed period from the date of purchase (see specific warranty period on reverse). This warranty shall be valid only if the product is purchased within the United States of America, including possessions and territories. It is the owner's responsibility to establish the date and place of purchase by acceptable evidence, at the time service is sought.
- B. For warranty service, you must obtain a Return Authorization number (RA#) before sending back the product—please contact ADJ Products, LLC Service Department at 800-322-6337. Send the product only to the Eliminator Lighting factory. All shipping charges must be pre-paid. If the requested repairs or service (including parts replacement) are within the terms of this warranty, Eliminator Lighting will pay return shipping charges only to a designated point within the United States. If the entire instrument is sent, it must be shipped in its original package. No accessories should be shipped with the product. If any accessories are shipped with the product, Eliminator Lighting shall have no liability whatsoever for loss of or damage to any such accessories, or for the safe return thereof.
- C. This warranty is void if the serial number has been altered or removed; if the product is modified in any manner which Eliminator Lighting concludes, after inspection, affects the reliability of the product, if the product has been repaired or service by anyone other than ADJ Products, LLC factory unless prior written authorization was issued to purchaser by Eliminator Lighting; if the product is damaged because not properly maintained as set forth in the instruction manual.
- D. This is not a service contract, and this warranty does not include maintenance, cleaning or periodic check up. During the period specified above, Eliminator Lighting will replace defective parts at its expense with new or refurbished parts, and will absorb all expenses for warrant service and repair labor by reason of defects in material or workmanship. The sole responsibility of Eliminator Lighting under this warranty shall be limited to the repair of the product, or replacement thereof, including parts, at the sole discretion of Eliminator Lighting. All products covered by this warranty were manufactured after August 15, 2012, and bear identifying marks to that effect.
- E. Eliminator Lighting reserves the right to make changes in design and/or improvements upon its products without any obligation to include these changes in any products theretofore manufactured.
- F. No warranty, whether expressed or implied, is given or made with respect to any accessory supplied with products described above. Except to the extent prohibited by applicable law, all implied warranties made by Eliminator Lighting in connection with this product, including warranties of merchantability or fitness, are limited in duration to the warranty period set forth above. And no warranties, whether expressed or implied, including warranties of merchantability or fitness, shall apply to this product after said period has expired. The consumer's and/or Dealer's sole remedy shall be such repair or replacement as is expressly provided above; and under no circumstances shall Eliminator Lighting be liable for any loss or damage, direct or consequential, arising out of the use of, or inability to use, this product.
- G. This warranty is the only written warranty applicable to Eliminator Lighting products and supersedes all prior warranties and written descriptions of warranty terms and conditions heretofore published.

LIMITED WARRANTY PERIODS

- **All Eliminator Lighting products (except laser diodes) = 1-year (365 days) Limited Warranty** (Such as: Special Effect Lighting, Intelligent Lighting, UV lighting, Strobes, Fog Machines, Bubble Machines, Mirror Balls, Par Cans, Trussing, Lighting Stands etc. excluding LED and lamps)
- **Laser Products = 1 Year (365 Days) Limited Warranty** (excludes laser diodes which have 6 month limited warranty)
- **Batteries = 180 Day Limited Warranty** (excluding batteries which have a 180 day limited warranty)

WARRANTY RETURNS

All returned service items, whether under warranty or not, must be freight pre-paid and accompanied by a return authorization (R.A.) number. The R.A. number must be clearly written on the outside of the return package. A brief description of the problem as well as the R.A. number must also be written down on a piece of paper and included in the shipping container. If the unit is under warranty, you must provide a copy of your proof of purchase invoice. Items returned without an R.A. number clearly marked on the outside of the package will be refused and returned at customer's expense. You may obtain an R.A. number by contacting customer support.

SAFETY GUIDELINES

To guarantee a smooth operation, it is important to follow all instructions and guidelines in this manual. Eliminator Lighting is not responsible for injury and/or damages resulting from the misuse of these devices due to the disregard of the information printed in this manual. Only qualified and/or certified personnel should perform installation of these devices and only the original rigging parts included with these devices should be used for installation. Any modifications to these devices and/or the included mounting hardware will void the original manufacturer's warranty and increase the risk of damage and/or personal injury.



THERE ARE NO USER SERVICEABLE PARTS INSIDE THIS DEVICE. DO NOT ATTEMPT ANY REPAIRS YOURSELF, AS DOING SO WILL VOID YOUR MANUFACTURER'S WARRANTY. DAMAGES RESULTING FROM MODIFICATIONS TO THIS DEVICE AND/OR THE DISREGARD OF SAFETY GUIDELINES IN THIS MANUAL VOID THE MANUFACTURER'S WARRANTY AND ARE NOT SUBJECT TO ANY WARRANTY CLAIMS AND/OR REPAIRS.



**NEVER REPLACE LAMP IN THIS FIXTURE WHILE IN USE!
UNPLUG POWER BEFORE REPLACING LAMP!
NEVER TOUCH FIXTURE DURING OPERATION, AS IT MAY BE HOT!
KEEP FLAMMABLE MATERIALS AWAY FROM FIXTURE!**



**INDOOR / DRY LOCATIONS USE ONLY!
DO NOT EXPOSE DEVICES TO RAIN AND/OR MOISTURE!**



**NEVER LOOK DIRECTLY INTO THE LIGHT SOURCE!
RETINA INJURY RISK - MAY INDUCE BLINDNESS!
SENSITIVE PERSONS MAY SUFFER AN EPILEPTIC SHOCK!**

SAFETY GUIDELINES

- DO NOT TOUCH fixture housing during operation.
- Turn OFF the power and allow approximately 15 minutes for the fixture to cool down before performing any repairs or maintenance.
- DO NOT shake fixture, and avoid brute force when installing and/or operating fixture.
- DO NOT operate fixture if the power cord is frayed, crimped, damaged and/or if any of the power cord connectors are damaged and do not insert into the fixture securely with ease.
- NEVER force a power cord connector into the fixture. If the power cord or any of its connectors are damaged, replace it immediately with a new cord or connector with the same power rating.
- DO NOT block any air ventilation slots. All fan and air inlets must remain clean and never blocked. Allow approx. 6" (15cm) between fixture and other devices or a wall for proper cooling.
- When installing the fixture in a suspended environment, always use mounting hardware that is no less than M10 x 25 mm, and always install fixture with an appropriately rated safety cable.
- Always disconnect fixture from main power source before performing any type of service and/or cleaning procedure.
- Only handle the power cord by the plug end, and never pull out the plug by tugging the wire portion of the cord.
- During the initial operation of this fixture, a light smoke or smell may emit from the interior of the fixture. This is a normal process and is caused by excess paint in the interior of the casing burning off from the heat associated with the lamp and will decrease gradually over time. Consistent operational breaks will ensure fixture will function properly for many years.
- ONLY use the original packaging and materials to transport the fixture in for service.
- **REPLACEMENT LAMP – LL-PAR 38 150W 110V LAMP**
- ALWAYS disconnect light from main power and allow 15 minutes for cooling before performing lamp replacement.
- NEVER remove the ground prong from the power cable.
- Power cords should be safely routed and secured so they are not likely pinched.
- Disconnect power cords during long periods of non-use.
- Only use recommended rigging hardware as described in this guide.
- The fixture should be serviced by qualified service personnel when:
 - A. The power-supply cord or the plug has been damaged.
 - B. Objects have fallen onto, or liquid has been spilled into, the appliance.
 - C. The appliance has been exposed to rain or water.
 - D. The appliance does not appear to operate normally or exhibits a marked change in performance.

MAINTENANCE GUIDELINES



DISCONNECT POWER BEFORE PERFORMING ANY MAINTENANCE!

CLEANING

Frequent cleaning is recommended to ensure proper function, optimized light output, and an extended life. The frequency of cleaning depends on the environment in which the device operates: damp, smoky, or particularly dirty environments can cause greater accumulation of dirt on the surface of the device and/or light fixture optics. Clean the external surface and the front lens of the light periodically with a soft cloth to avoid dirt/debris accumulation

NEVER use alcohol, solvents, or ammonia-based cleaners.

MAINTENANCE

Regular inspections are recommended to insure proper function and extended life. There are no user serviceable parts inside these devices. Please refer all other service issues to an authorized ADJ service technician. Should you need any spare parts, please order genuine parts from your local ADJ dealer.

Please refer to the following points during routine inspections:

- A detailed review by an approved electrical engineer every three months, to make sure the circuit contacts are in good condition and prevent overheating.
- Be sure all screws and fasteners are securely tightened at all times. Loose screws may fall out during normal operation, resulting in damage or injury as larger parts could fall.
- Check for any deformations on the light housing, lens, gel frame, rigging hardware and rigging points (ceiling, suspension, trussing). Deformations could allow for dust to enter into the devices. Damaged rigging points or unsecured rigging could cause the devices to fall and seriously injure a person(s).
- Electric power supply cables must not show any damage, material fatigue, or sediments.

OVERVIEW

INCLUDED ITEMS:

- (x1) Metal Par Can with Power Cord
- (x1) LL-Par 38 Lamp
- (x1) Socket
- (x1) Gel Frame

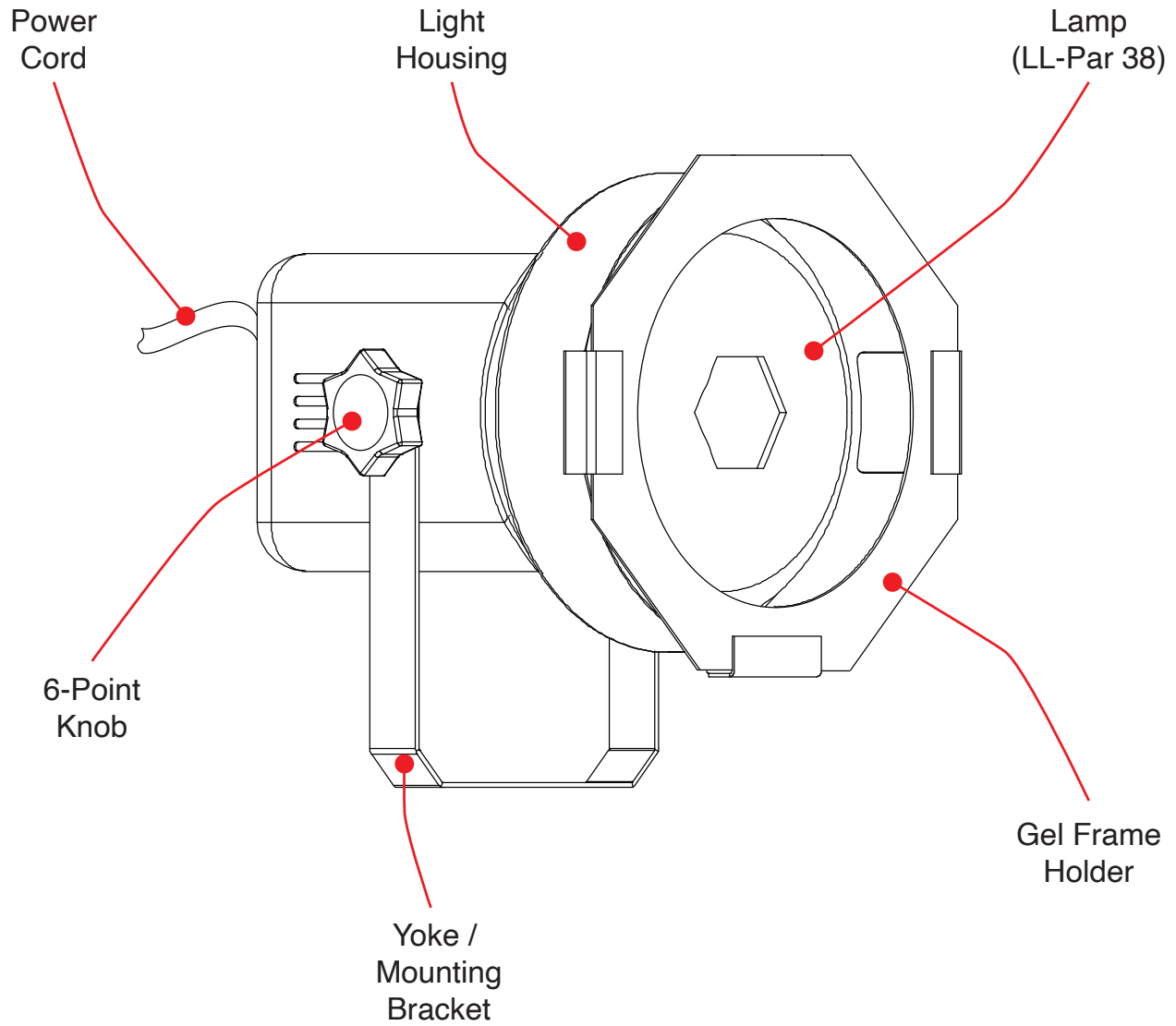

INSTALLATION



FLAMMABLE MATERIAL WARNING

Keep devices minimum 5.0 feet (1.5m) away from flammable materials and/or pyrotechnics.



ELECTRICAL CONNECTIONS

A qualified electrician should be used for all electrical connections and/or installations.



DO NOT INSTALL THIS DEVICE IF YOU ARE NOT QUALIFIED TO DO SO!

OVERHEAD RIGGING REQUIRES EXTENSIVE EXPERIENCE, INCLUDING CALCULATING WORKING LOAD LIMITS, KNOWLEDGE OF INSTALLATION MATERIAL BEING USED, AND PERIODIC SAFETY INSPECTION OF ALL INSTALLATION MATERIAL, AMONG OTHER SKILLS. IF YOU LACK THESE QUALIFICATIONS, DO NOT ATTEMPT THE INSTALLATION YOURSELF. IMPROPER INSTALLATION CAN RESULT IN BODILY INJURY.

BEFORE RIGGING/MOUNTING FIXTURE TO ANY METAL TRUSS/STRUCTURE OR CEILING, A PROFESSIONAL EQUIPMENT INSTALLER MUST BE CONSULTED TO DETERMINE WHETHER THE METAL TRUSS/STRUCTURE OR CEILING IS PROPERLY CERTIFIED TO SAFELY HOLD THE WEIGHT OF THE FIXTURE. THE MOUNTING SURFACE OR STRUCTURE MUST BE CAPABLE OF SUPPORTING A MINIMUM POINT LOAD OF 10 TIMES THE WEIGHT OF THE DEVICES.

MAKE SURE SCREWS AND/OR ANCHOR BOLTS (NOT INCLUDED) FIT SECURELY INTO MOUNTING HOLES!

MAKE SURE TO DRILL SCREWS AND/OR ANCHOR BOLTS INTO WOOD OR METAL! DO NOT MOUNT THE FIXTURE TO A CEILING OR SURFACE MADE OF DRY WALL!

FOR ADDED PROTECTION, MOUNT FIXTURE AWAY FROM WALKING PATHS, SEATING AREAS, OR AREAS IN WHICH UNAUTHORIZED PERSONNEL CAN REACH THE FIXTURE.

NEVER STAND DIRECTLY BELOW THE FIXTURE WHEN MOUNTING, REMOVING, OR SERVICING.

FIXTURE MUST ALL BE INSTALLED FOLLOWING ALL LOCAL, NATIONAL, AND COUNTRY COMMERCIAL ELECTRICAL AND CONSTRUCTION CODES AND REGULATIONS.

DO NOT EXCEED AMBIENT OPERATING TEMPERATURE RANGE OF 140°F. (60°C)

INSTALLATION

AIMING THE LIGHT SOURCE

Experiment with different angles and distances before mounting the light in its final position in order to achieve the desired result.

MOUNTING LIGHT SOURCE

The light can be mounted onto a truss using a properly rated clamp (not included), or to a flat surface using the mounting hole on the top of the bracket/yoke. Any mounting surface must be able to support at least 10 times the total weight of the light. ***Please consult a professional for ceiling installation guidance.***

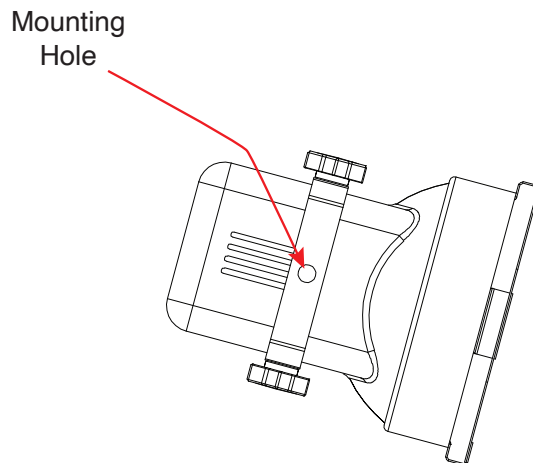

ADJUSTING THE AIM

To adjust the aim of the fixture, loosen the 6-point knobs on each side of the yoke by turning counter-clockwise. Adjust the aim of the light as needed, then secure in place by re-tightening the knobs clockwise.

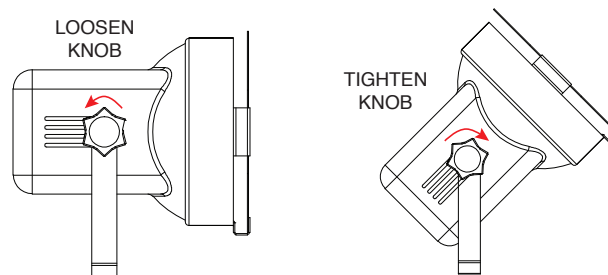

GEL FRAME

Gel sheets (optional) can be used to modify the light output of the fixture. To use a gel sheet, slide the gel frame upwards from the light fixture and place a gel sheet in the frame. Trim the gel sheet, if desired, and reinstall the gel frame by sliding it back into the fixture.

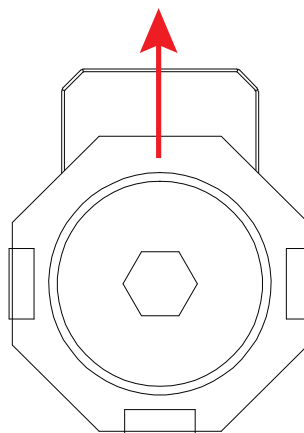

LAMP REPLACEMENT

Make sure light is disconnected from the power source, and allow 15 minutes for the fixture to cool if has been operating. Remove the gel frame, then unscrew bulb by turning counter clockwise. Replace bulb and reassemble the fixture.

TROUBLE SHOOTING

The light does not turn on.

- Confirm the light is connected to AC power.
- Check the circuit breaker that controls the AC outlet the light is plugged into, and reset or replace the breaker if it has been tripped.
- Confirm the AC power cord from the light is not damaged or cut.
- Confirm the light bulb is not damaged or loose.
- If none of these solutions work, please contact ADJ Customer Service.

FREQUENTLY ASKED QUESTIONS

Can the fixture be mounted onto to a ceiling?

Yes, it can be affixed to any flat ceiling surface that can support at least 10 times the combined total weight of the fixture and any mounting accessories. Careful planning must be used when calculating the combined weight and determining if the flat ceiling surface can support the weight of the fixture.

PLEASE CONSULT A PROFESSIONAL FOR CEILING INSTALLATION GUIDANCE!

What kind of replacement bulb does this fixture need?

Replacement Lamp: LL-PAR 38 150W 110V LAMP

How do you clean the light fixture?

Clean the external surface and lens periodically with a soft cloth to avoid dirt/debris accumulation. NEVER use alcohol, solvents, or ammonia-based cleaners.

Is this fixture DMX compatible?

No. However, Eliminator offers a variety of lighting fixtures and options, many of which include DMX capability. Please visit our website at www.adj.com for details.

Can the light stand freely on the floor?

Yes, but Eliminator recommends mounting the fixture to a base or fixed mounting point for best results.

SPECIFICATIONS

- Black metal Par 38 Par Can
- Includes: hanging bracket, power cord, gel frame and halogen lamp
- Replacement Lamp: Lamp Lite LL-PAR 38 (150W, 110V)
- Dimensions: 6.42" x 7.56" x 7.76" / 163mm x 187mm x 197mm
- Weight: 1.81 lbs. / 0.82 kgs.
- Electrical: AC 120V/60Hz
- CE Certified

DIMENSIONAL DRAWINGS

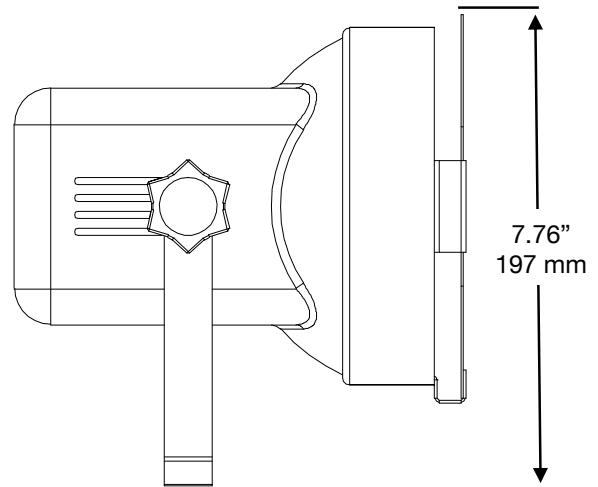
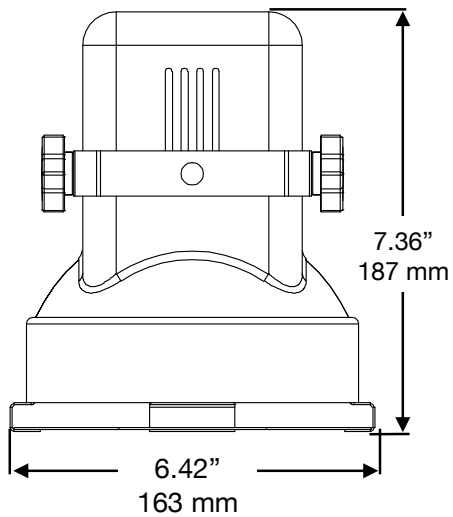

This page intentionally left blank.

